

Hi Tech

Gasket

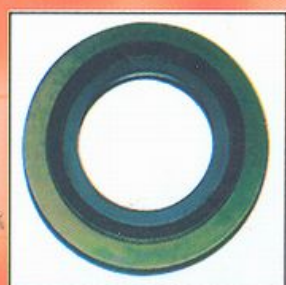

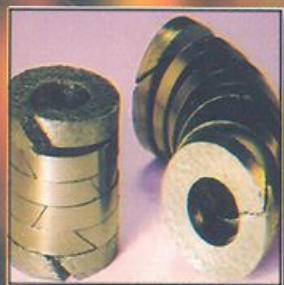
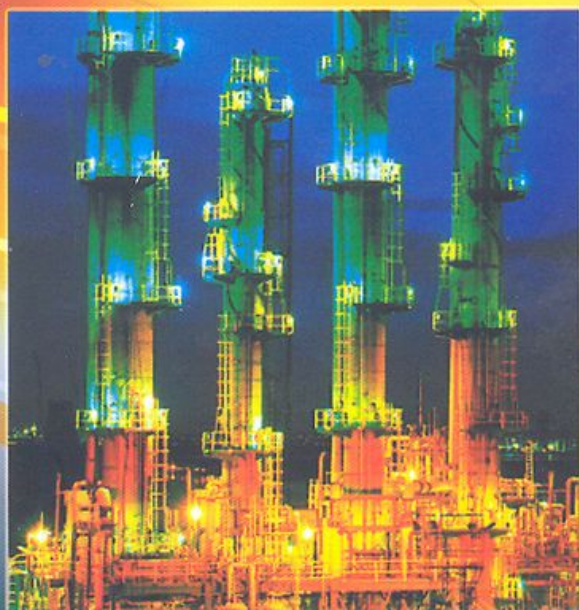

Introduction . . .

Hi-TECH Gasket manufacture the highest performing sealing devices including Spiral Wound Gasket, Heat Exchanger Gasket, Double Jacketed Gasket, PTFE Gasket & Sheet, Graphite Gasket & Sheet, Cork, Rubber-cork Sheet, Non-Asbestos Gasket & Sheet and a range of Packing material for a wide range of applications.

Gasketing and Packing are considered by some to be technologies of the past. At Hi-TECH Gaskets, we continuously research and advance the state-of-the-art for Gasketing & Packing

Our advanced packings provide such benefits as superior leakage and emission control, the ability to operate at high pressures and speeds, and the ability to withstand process chemicals and reduce sleeve and stem scoring.

Our sheet gasketing features high stability, reinforced synthetics that provide excellent sealability and super reliability.

Our joint sealants provide long lasting high reliability seals that are fast and easy to use.

As a result of relentless push for quality, plus continuous research and design efforts, we can offer products that provide superior value. We back these products with outstanding customer service, technical support and delivery.

In these pages you will find an overview of our quality products. Detailed information is also available on each individual product. Hi-TECH Gaskets specialist can assist you in the development of coherent maintenance programs that increase efficiency, performance and productivity. We offer the future of Gasketing and Packing Technology today.



OUR MISSION

Provide innovative and cost effective total sealing solutions for Oil & Gas, Chemicals, Petrochemical, Power, Mining, Marine, Fluid Transportation, Engineering Industries etc. by manufacturing and trading of world class quality products.

OUR VISION

To be the leading manufacturer of quality products in the Middle East.
To be the first choice company to our Employees, Customers and Suppliers.
To be professionally managed company.



GASKET	SPIRAL WOUND GASKET	01
	NA SPIRAL WOUND GASKET	02
	PTFE SPIRAL WOUND GASKET	02
	GRAPHITE SPIRAL WOUND GASKET	03
	PTFE CUSHION GASKET	03
	HEAT EXCHANGER GASKET	04
	METAL JACKETED GASKET	05
	GRAPHITE GASKET	05
	NON-CIRCULAR SPIRAL WOUND GASKET	06
	SOLID METAL GASKET	07
	SERRATED METAL GASKET	07

CONTENTS

PACKING	FLEXIBLE GRAPHITE PACKING	08
	GRAPHITE BRAIDED TUBE/ROUND PACKING	09
	GRAPHITE BRAIDED PACKING	09
	ACRYLIC FIBRE BRAIDED PACKING	09
	CARBONIZED FIBER BRAIDED PACKING	10
	CARBON FIBER PACKING	10
	PTFE PACKING	10
	PTFE FIBER PACKING	11
	KEVLAR BRAIDED PACKING	11
	KEVLAR+PTFE/GRAPHITE PACKING	11
	MOLDED RINGS	12
	PACKING RINGS	16

SHEETS & SEALS	NON-ASBESTOS SHEET	17
	CORK & RUBBER CORK SHEET	18
	EXPANDED GRAPHITE SHEETS & ROLLS	18
	REINFORCED EXPANDED GRAPHITE SHEET	19
	PTFE/TEFLON SHEET, GASKET & SEALS	20
	SEALON SHEET (GASKET), JOINT SEALANT & ROPE	20

Warning ! All statements in this catalogue pertaining to pressure, chemical compatibility, temperature, and service ratings are based on general service experience. Because of the wide variety of applications of our products, the broad range of products available, and the wide range of equipment conditions encountered, together with the unpredictable human factors involved in the installation of these products by the ultimate user, we do not encourage reliance on recommendations shown without specific prior service experience. Failure to select the proper sealing products could result in property damage and/or serious personal injury.

While utmost care has been used in compiling this brochure, we assume no responsibility for errors. Specific data on materials, construction methods, installation and troubleshooting procedures are subject to change without notice.

For the reasons indicated, the Hi-Tech Gasket makes no warranties, expressed or implied, that products described are guaranteed for any length of time, for any measure of service, or for any specific purpose.



SPIRAL WOUND GASKET

Spiral Wound Gasket is the ideal gasket in the semi-metallic category. A narrow strip of V-shape metal hoop is spirally wound under tension with a filler cushion between the lamination of the metal and is spot-welded at both ends.

This unique construction of a spring-like metal and soft filler provides gasket excellent characteristics.

Resistance to high temperature and high pressures.

Great resilience which allows the gasket to adjust automatically to change in operating conditions, such as pressure and thermal shocks, vibrations etc.

Excellent sealability is maintained with comparatively small gasket area.

Good tolerance for flange surface finish irregularities.

Can be designed to any dimensions economically in circular or moderately noncircular shape.

Available in a variety of hoop metals and filler materials to satisfy specific operating conditions.

Material & Structure

Type	Cross section	Hoop material	Filler material	Inner, Outer ring material	Normal Thickness	
					V-shaped	W-shaped
Basic type		SUS 304 316 / L, 321, Ti, Monel etc. As specified Stainless steel tape.	Non-asbestos	Carbon steel or SUS 304 316/ L etc. As specified	3.2	2.5
With inner ring					4.5	4.8
With outer ring			PTFE		4.5	5.5
With inner & out ring			4.5		7.5	

Cross section and Number

Type	Hoop material	Non-asbestos	Graphite	PTFE
Basic type	SUS304	204	304	404
	SUS316/ L	206	306	406
	As specified	209	309	409
With inner ring	SUS304	214	314	414
	SUS316 / L	216	316	416
	As specified	219	319	419
With outer ring	SUS304	224	324	424
	SUS316 / L	226	326	426
	As specified	229	329	429
With inner & out ring	SUS304	234	334	434
	SUS316 / L	236	336	436
	As specified	239	339	439



NA SPIRAL WOUND GASKET

HI TECH NO. HTG200



Instead of the conventional asbestos filler, this type uses inorganic fibers and aramid fibres as a nonasbestos paper filler.

Features :

1. Asbestos fibers not used.
2. The service range(heat resistance, pressure resistance) is different from that of the asbestos SWG, but the sealing performance is almost the same.

Applications

Suitable for use in piping flanges, pressure vessels, heat exchangers, valve bonnets, etc., in a variety of industries, especially in locations where asbestos is not allowed.

Service Range

Fluid	Maximum service temperature °C	Maximum service pressure
Water type fluids	350	Class 1500
Oil type fluids	350	Class 600
Gas type fluids	350	Class 400

PTFE SPIRAL WOUND GASKET

HI TECH NO. HTG300 SERIES

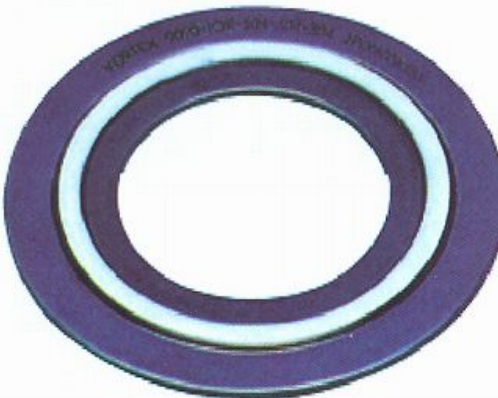

The gasket uses unsintered PTFE tapes as the filler material. The PTFE filler provides superior chemical resistance and sealability with strongly corrosion resistant metals, it can be applied for corrosive fluids, pure oxygen gas and vacuum lines.

Features:

1. Sealability is superior to that of other SWG gasket. Usage is possible even with vacuum lines.
2. Excellent corrosion resistance makes it suitable for almost all types of fluid by selecting appropriate hoop materials.
3. Not used for glass or rubber lined flange, glass or porcelain flange.

Service Range

Fluid	Maximum service temperature °C	Maximum service pressure
Water type fluids	300	Class 600
Oil type fluids	300	Class 600
Gas type fluids	300	Class 600



GRAPHITE SPIRAL WOUND GASKET

HI TECH NO. HTG400 SERIES



The gasket uses expanded graphite tape as the filler material which provides superb sealability even under severe conditions such as high temperature, high pressure, cryogenic temperatures, heat cycles, temperature cycles and so on.

Feature

1. Sealing, especially gas sealing, is superior to that of asbestos gaskets.
2. Little deterioration of the filler material at high temperatures, outstanding long-term sealability even under high temperatures and high pressures.
3. Sealing remains outstanding even under severe conditions such as pressure fluctuations and heat cycles.
4. Excellent sealability is maintained making it possible to apply this for corrosive fluids by selecting the appropriate materials.
5. Outstanding sealing even at cryogenic temperatures.

Service Range

Fluid	Maximum servicetemperature °C	Maximum service pressure
Water type fluids	300	Class 600
Oil type fluids	300	Class 600
Gas type fluids	300	Class 600

PTFE CUSHION GASKET

HI TECH NO. HTG800 SERIES

Type & Structure

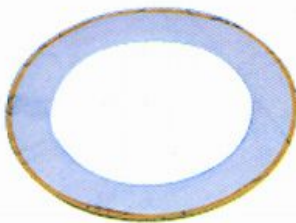

No.	Cross section	Description
HTG810		V Type, PTFE disc slit in center from outside
HTG820		U Type, PTFE tape heat sealed at one joint
HTG830		L Type, PTFE sheet machine cut to envelope form

Service Range

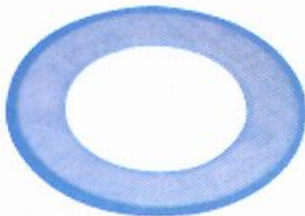

Material of Jacket	Cross section	Temperature (°C)	Pressure (Mpa)
Non-asbestos Joint Sheet		200	2
Non-asbestos Joint Sheet between layers of Non-asbestos millboard		220	2.5



HEAT EXCHANGER GASKET

HI-TECH NO. : EX SERIES

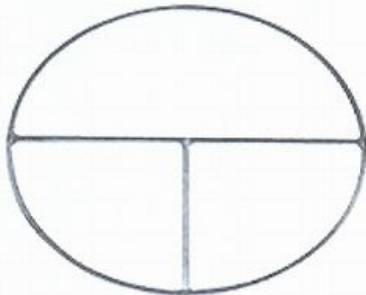

This EX series gasket is designed and manufactured for multi-pass heat exchangers. Pass ribs are welded to inner hoop of gasket or inner ring. 2 type of pass ribs are available. Tube type or Metal jacket type.

EX series gasket are available for non-asbestos, PTFE, graphite. For tongue and groove flange, stainless steel rod (SS304,316 / L 3.2mm) fixed in circumferential groove of the inner hoop is also available on request.

Max Pressure : 25Mpa

Max Temperature : 550°C

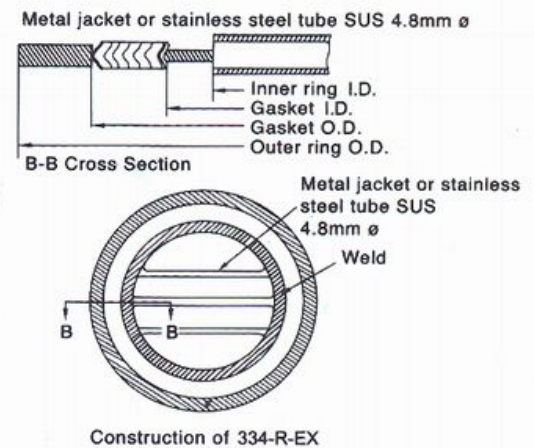
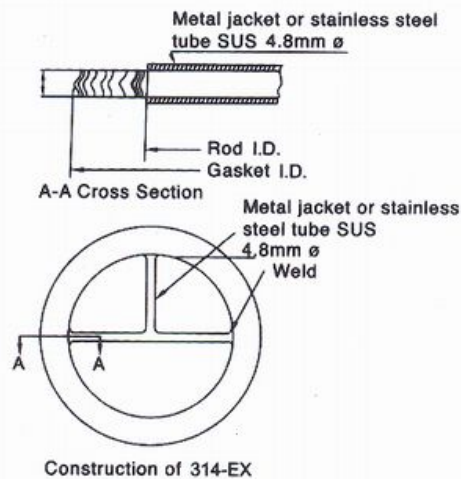

Type

Type	HI TECH NO.	Hoop Material	Shape(Cross Section)
Basic with Rod Attached (For T & G Flange)	X14-EX	SUS304	
	X16-EX	SUS316 / L	
	X19-EX	As specified	
Inner Ring Attached	X14-EX	SUS304	
	X16-EX	SUS316 / L	
	X19-EX	As specified	
Outer Ring Attached	X24-EX	SUS304	
	X26-EX	SUS316 / L	
	X29-EX	As specified	
Inner & Outer Ring Attached	X34-EX	SUS304	
	X36-EX	SUS316 / L	
	X39-EX	As specified	

X indicates filler

1-Non-asbestos 2-Graphite 3-PTFE



METAL JACKETED GASKET

HI TECH NO. HTG500 SERIES



It is made from Non Asbestos millboard, Expanded Graphite Ceramic, PTFE etc. filler, covered with thin metal jacket, such as stainless steel, carbon steel, copper etc. Proper medium, pressure and temperature are decided by different materials we use. The highest temperature is 1300°C and the highest pressure is up to 10 Mpa.

Type & Structure

No.	Description	Cross section	Filler material
HTG501	Single-Jacketed		Ceramic fiber
HTG502	Wholly-Jacketed		
HTG503	Corrugated-Jacketed		Flexible graphite
HTG504	Corded-Jacketed		PTFE
HTG505	Double-Jacketed		Non-asbestos
HTG506	Another Kings Jacketed		

Service Range

Material of Jacket	Max. Temperature (°C)	Pressure (Mpa)
Carbon steel	300	2-6
Copper	400	2-6
Stainless steel such as AISI 304, 316 etc.,	530	2-6

GRAPHITE GASKET

HI TECH NO. HTG850,850E SERIES

850 Series Graphite gaskets are cut from pure graphite sheet or graphite sheet with metal reinforcement, features excellent corrosion-resistance, high-and-low temperature resistance, good compression resilient and high intensity it can be used as sealing elements of pipe, valve, pump, pressure vessel, heat exchanger and condenser, etc. Other complex gaskets such as water gauge gasket and flange gasket with bolt holes are available.

850E Series, it is improved 850 series, wrapped with metallic stripe in the inner and outer circle borderline. Keep the former excellent performances. Can be installed and disassembled conveniently without damage.

Thickness : 1.5mm, 2.0mm, 3.0mm, 4.5mm



Application	Flanges, valve bonnets, heat exchangers, level indicators etc.
Typical Service Fluids	High temperature & pressure steam, hot water, gases, heat midium, hydrocarbon, organic solvents, acids, alkalis (PH0-14), LPG,LNG,liquefied oxgen, nitrogen and hydrogen etc.

Type

NO.	Name	Constructuion	Pressure (Mpa)	Temperature(°C)	
				Redcing Atmosphere	Oxidizing Atmosphere
HTG850	Pure graphite gasket		3	-240~1650	-240~400 -240~870 (SS316 / L)
HTG851	Reinforced graphite gasket with punched metal		5	-240~450	-10~450(CS) -240~560 (SS304)
HTG852	Reinforced graphite gasket with adhesive metal		5	-240~450	-200~560 (SS304) -200~870 (SS316 / L)



NON-CIRCULAR SPIRAL WOUND GASKET

HI TECH NO.: M SERIES



Spiral Wound M series are designed and manufactured for boiler manholes and handholes, valve bonnet covers etc. In required shapes and dimensions for service pressure range from 150LB to 2500LB. 1504-M is manufactured with SUS 304 and non-asbestos paper filler, and 1506-M with SUS316. 1509-M is manufactured with other metals on request.

Other asbestos free types are also available on request.

Service Temperature 1504-M: up to 500°C

1506-M: up to 580°C

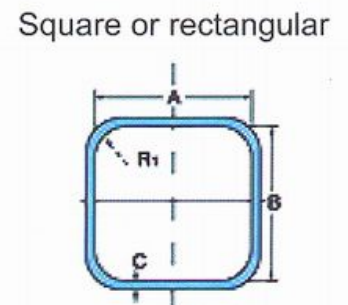
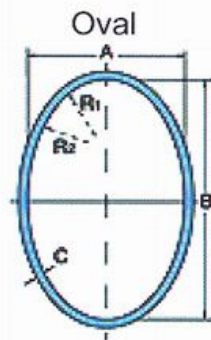
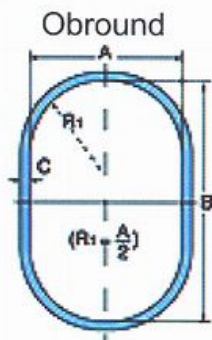

Flange types and suitable gasket types

Full face
(FF)

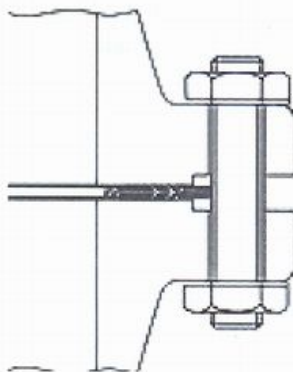

with inner and
outer ring

Raised face
(RF)

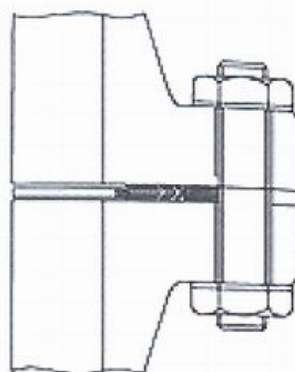

with inner and
outer ring

Male & Female
(M & F)

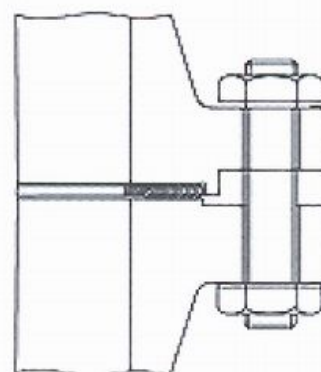

with inner ring

Tongue & Groove
(T & G)

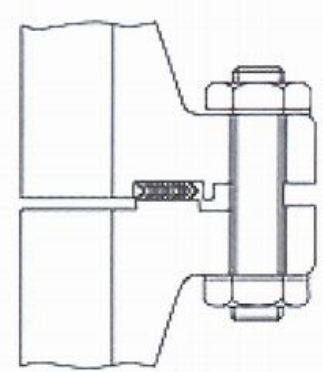

Basic type

The type without an inner ring can be used if the following conditions are fully satisfied.

Filler material: Non asbestos

Pressure rating: Class 600 or below, or 40K or below.

Size: Nominal diameter 24B or below, or 600A or below.



SOLID METAL GASKET

HI TECH NO. HTG650

Type & Structure



Machined from solid metals in a variety of shapes and are designed for high pressure, high temperature or highly corrosive applications by selecting the most suitable material and shapes.

No.	Description	Cross section	
HTG651	Oval type		 HTG651
HTG652	Octagonal type		
HTG653	API-EX type		
HTG654	API-EX type		
HTG655	Plain type		
HTG656	Lens type		 HTG652
HTG657	Delta type		
HTG658	Wedge-shape type		
HTG659	Double cone type		
HTG660	O type inside spring		

Service Range

Material	Max.Hardness	Max.Temperature (°C)
Low Carbon Steel(S 10 °C)	120	530
Stainless steel sheet such as,SS304 316 etc.	160	750
Copper	50	400
Aluminium	30	300
Lead	10	100

SERRATED METAL GASKET

HI TECH NO. HTG650 SERIES



Flat ring with concentric serrations made of various types of metal. Used when bolting force is not sufficient to seal a flat gasket, because it contacts flange face only at serration peaks. Commonly used on valve bannets and flanges attached to equipment. 3 types of cross section as per right table are available.

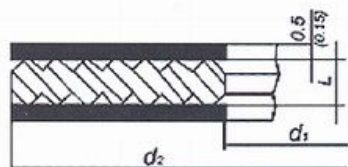
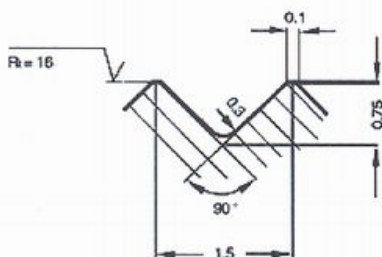

Type & Cross Section

Type	Cross Section
Basic(A)	
With outer Ring(B)	
With inner and Outer ring(C)	

Depth of Serration(t)

Width / Thickness	4.5mm	3.0mm	Cross Section
Less than 10mm	Inner diameter less than 200mm; 0.75mm Inner diameter 200 mm or Over : 1.0 mm	0.5mm	
10mm and above	1.0mm		



FLEXIBLE GRAPHITE PACKINGS

HI TECH NO. HTP200 SERIES



The packings braided by technology of braiding around a core (or cores) or mutipie sieve braid etc. have more perfect safe properties on sealing. They are the best composite parts for solving sealing problem. In addition, according to conditions of different corrosive circumstances and customer's demands, the packings can be treated with inhibitors of corrosion to make their anticorrosive property better. These products are almost suitable to all media, such as: hot water steam, oil, heat-exchanging liquids, acids, alkalis, ammonia, hydrogen, organic solvents, hydrocarbons, low temperature liquids etc.

They can be applied to the equipments and devices in petroleum, electricity generation, chemical pharmaceutical and light industries.

NO:	Type of Reinforcing Fiber for Braided Flexible Graphite Packing	Density(g/cm ³)	size
HTP201	Braided flexible graphite packing reinforced by cotton fiber	0.9~1.3	1/8"~2"
HTP202	Braided flexible graphite packing reinforced by cotton fiber + stainless steel + wire		
HTP203	Braided flexible graphite packing reinforced by cotton fiber + Inconel wire		
HTP204	Braided flexible graphite packing reinforced by glass fiber		
HTP205	Braided flexible graphite packing reinforced by glass fiber + stainless steel wire		
HTP206	Braided flexible graphite packing reinforced by glass fiber + Inconel wire		
HTP207	Braided flexible graphite packing reinforced by cotton + 304 wires		3~50mm
HTP208	Braided flexible graphite packing reinforced by carbon fiber		
HTP209	Braided flexible graphite packing reinforced by cotton fiber + carbon fiber		
HTP210	Braided flexible graphite packing reinforced by cotton fiber + Kevlar fiber		
HTP211	Braided flexible graphite packing reinforced by outside-braided Inconel wire + cotton fiber		
HTP212	Braided flexible graphite packing reinforced by outside-braided Inconel wire + glass fiber		
HTP213	Braided flexible graphite packing reinforced by Inconel wire		

Note : Other reinforcing fibers and their combination can be supplied according to customers demands

Dimensions

mm	3	4	5	6	8	10	11	12	14	16	18	19	20	22	25
inch	1/8"	5/32"	3/16"	1/4"	5/16"	3/8"	7/16"	1/2"	9/16"	5/8"	11/16"	3/4"	13/16"	7/8"	1"
m/kg abt.	90	50	32	23	13	8.3	7	5.8	4.5	3.5	2.7	2.5	2.2	1.9	1.5

**GRAPHITE BRAIDED TUBE/ROUND PACKING****HI TECH NO. HTP201B**

Made of 100 series flexible graphite yarn through reinforcing and braiding, the section is rectangle/round, instead of normal square section. Applicable for underly packing material of pumps, valves and vessels.

Other performances are same as 200 series

Dimensions

mm	3	4	5	6	8	10	11	12	14	16	18	20	22	25
inch	1/8"	5/32"	3/16"	1/4"	5/16"	3/8"	7/16"	1/2"	9/16"	5/8"	11/16"	3/4"	7/8"	1"
m/kg abt.	50	34	25	15	10	7.1	5.3	4.1	3.6	2.8	2.3	1.8	1.4	1.1

GRAPHITE BRAIDED PACKING**HI TECH NO. HTP223 SERIES**

It is a flexible and high strength braided packing which is made of an innovative expanded pure graphite yarn white inconel wire reinforcement. The combination of other braided packings installed with the excellent sealing capabilities of expanded graphite makes most effective sealing component, especially in the presence of high pressure. It can be used to seal hot water, high temperature and pressure steam, heat transfer fluid, hydrogen gas, ammonia, organic, solvents, hydrocarbons, cryogenic liquids, etc., except fewer strong oxidizer. It also is a unique and universal sealing packing.

Dimensions

mm	3.2	4.8	6.4	7.9	9.5	11.1	12.7	15.9	19.0	22.2	25.4
inch	1/8"	3/16"	1/4"	5/16"	3/8"	7/16"	1/2"	5/8"	3/4"	7/8"	(1)
KG/3M	-	0.095	0.16	0.24	0.34	0.47	0.65	1.06	1.39	1.73	2.28

ACRYLIC FIBRE BRAIDED PACKING**HI TECH NO: HTP240 HTP241**

Made of polyacrylonitrile fibre through reinforcing braiding and impregnated with PTFE, having high strength, wear-and impact-resistance, and ideal substitute for asbestos packings, and applicable for packing seal of pumps, valves and vessels at a high linear speed and pressure.

HTP 241s has the same basic materials, process and applications as HTP 240.

Silicone rubber elastomer provided in central position to improve compression power.

Dimensions

mm	3	4	5	6	8	10	11	12	14	16	18	20	22	25
inch	1/8"	5/32"	3/16"	1/4"	5/16"	3/8"	7/16"	1/2"	9/16"	5/8"	11/16"	3/4"	7/8"	1"
m/kg abt.	50	33	23	14	9.1	6.4	4.8	3.6	3.1	2.3	2.0	1.6	1.2	0.9

**CARBONIZED FIBER BRAIDED PACKING****HI TECH NO. HTP260 SERIES**

The packing is manufactured in the following procedures: polyacrylonitrile fibre is heated into carbonized fibre, which is woven into packing after impregnation in PTFE dispersion containing graphite particles, It is used as dynamic sealing in the presence of media of weak acid or alkaline, or media that contain few grains of solid particles.

Dimensions

mm	3	4	5	6	8	10	11	12	14	16	18	20	22	25
inch	1/8"	5/32"	3/16"	1/4"	5/16"	3/8"	7/16"	1/2"	9/16"	5/8"	11/16"	3/4"	7/8"	1"
m/kg abt.	60	41	27	16	10	7.9	5.8	4.5	3.3	2.9	2.5	2	1.5	1.1

CARBON FIBER PACKING**HI TECH NO. HTP270 SERIES**

The packing is woven of strong carbon fiber after softening treatment and impregnation with the mixture of fine graphite powder, PTFE dispersion and lubricant. Being strong, static and heat-conductive, it is widely used with revolving or reciprocating pumps, where media of chemical corrosion and grains of particles exit.

Dimensions

mm	3	4	5	6	8	10	11	12	14	16	18	20	22	25
inch	1/8"	5/32"	3/16"	1/4"	5/16"	3/8"	7/16"	1/2"	9/16"	5/8"	11/16"	3/4"	7/8"	1"
m/kg abt.	50	40	27	15	10	7.5	5.6	4.3	3.1	2.8	2.4	1.9	1.4	1.1

PTFE PACKING**HI TECH NO. HTP280 SERIES**

PTFE packing is a braided packing made from PTFE Yarn, PTFE dispersion and lubricant are not impregnated. Recommended for IC related lines. finechemicals, foods, pharmaceuticals where contamination is not allowed. It can be used to seal all chemicals except molten alkali metals.

Dimensions

mm	3	4	5	6	8	10	11	12	14	16	18	20	22	25
inch	1/8"	5/32"	3/16"	1/4"	5/16"	3/8"	7/16"	1/2"	9/16"	5/8"	11/16"	3/4"	7/8"	1"
m/kg abt.	60	41	27	16	10	7.3	5	3.8	3.4	2.7	2.2	1.8	1.4	1.1



PTFE FIBER PACKING



HI TECH NO. HTP285

PTFE fiber packing is a pure yarn PTFE fiber packing braided into square cross section and impregnated with PTFE dispersion.

High cross-sectional density and structural strength. Inert to almost all chemicals and has great resistance to mechanical attack. Low coefficient of friction results in easy shaft running. Long service duration is ensured as PTFE yarns are stable and there is no lubricant squeezed out under operating pressure.

Dimensions

mm	3	4	5	6	8	10	11	12	14	16	18	20	22	25
inch	1/8"	5/32"	3/16"	1/4"	5/16"	3/8"	7/16"	1/2"	9/16"	5/8"	11/16"	3/4"	7/8"	1"
m/kg abt.	50	33	23	14	9.1	6.4	4.8	3.6	3.1	2.3	2.0	1.6	1.2	0.9

KEVLAR BRAIDED PACKING



HI TECH NO. HTP300 SERIES

Universal packing which can be used for pumps in all types of industry such as chemicals, petrochemicals, sewage treatment, paper etc. For hot water applications, it can be used uncooled up to 160°C. In view of the high stability of aramide fibres we recommend a surface hardness of 40 - 60 HRC for shafts and protective sleeves in order to prevent contact surface wear.

Dimensions

mm	3	4	5	6	8	10	11	12	14	16	18	20	22	25
inch	1/8"	5/32"	3/16"	1/4"	5/16"	3/8"	7/16"	1/2"	9/16"	5/8"	11/16"	3/4"	7/8"	1"
m/kg abt.	50	34	25	15	10	7.1	5.3	4.1	3.6	2.8	2.3	1.8	1.4	1.1

KEVLAR+PTFE/GRAPHITE PACKING



HI TECH NO. HTP310 SERIES

High-quality combination of PTFE with incorporated graphite and additional reinforcement of sliding surface of aramid yarn. Good sliding velocity and thermal conductivity. It is recommended for centrifugal pumps with high pressure and sliding velocity as well as for abrasive media. It can be for water, sewage water, hot water, oil, greases, weak acids and alkaline, etc.

Dimensions

mm	3	4	5	6	8	10	11	12	14	16	18	20	22	25
inch	1/8"	5/32"	3/16"	1/4"	5/16"	3/8"	7/16"	1/2"	9/16"	5/8"	11/16"	3/4"	7/8"	1"
m/kg abt.	50	36	26	17	10	7.2	5.3	4.1	3.6	2.6	2.3	1.9	1.4	1.1



MOLDED RINGS

HT P211



**PTFE molded
packing ring**

HT P212



**Lubricated PTFE fiber
molded packing ring**

HT P214



**Graphite PTFE fiber molded
packing ring with oil**

HT P218



**Aramid fiber PTFE
molded packing ring**

HT P219



**Carbon fiber PTFE
molded packing ring**

HT P220



**Carbon fiber graphite
PTFE molded packing ring**



MOLDED RINGS

HT P226



Asbestos molded packing ring with inonel wire insertion, lubricated and graphited

HT P229



Asbestos PTFE molded packing ring

HT P230



Asbestos PTFE molded packing ring with oil

HT P216



PTFE with Aramid fiber reinforced molded packing ring

HT P217



Graphite PTFE with Aramid fiber reinforced molded packing ring

HT P223



Inconel wire reinforced graphited fiber molded packing ring



MOLDED RINGS

HT P227



Asbestos graphite molded packing ring with brass wire insertion

HT P231



Aramid fiber PTFE fiber braided and molded packing ring

HT P232



Aramid fiber graphite PTFE fiber braided and molded packing ring

HT P233



Graphite PTFE with PTFE fiber reinforced molded packing ring

HT P233



Graphite PTFE with PTFE fiber reinforced molded packing ring

HT P234



Non-asbestos fiber molded packing ring



HT P235



Inconel wire reinforced
asbestos molded packing ring

HT P236



PTFE with synthetic fiber reinforced
in corners molded packing ring

HT P237



Graphite PTFE with synthetic
fiber reinforced molded packing ring

HT P238



Synthetic fiber with graphite
PTFE fiber molded packing ring

HT P239



High pressure graphite
molded packing ring

HT P240



Oil-resistant asbestos
molded packing ring



PACKING RING



Made through molding of flexible graphite materials and various braided packings.

Applications: Packing sealing for valves, pumps and reaction vessels.

Specifications available: 10 - 1000mm



TYPE OF CUTTING

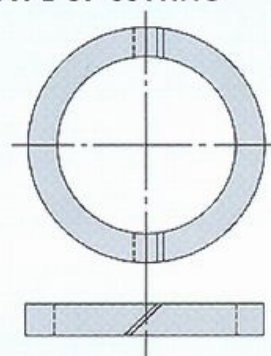

Split Type (2 cut)

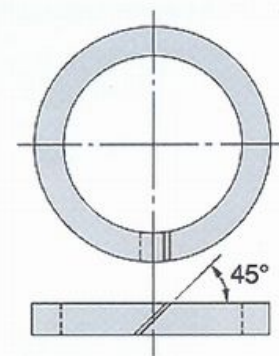

Bias Cut Type (1 cut)

Code	Product
HTP010	Flexible graphite ring
HTP011	High-purity flexible graphite ring
HTP012	Nuclear installation-purpose flexible graphite ring
HTP013	Reinforcing material-bearing flexible composite ring
HTP020	Flexible graphite braided packing ring
HTP225	Asbestos impregnated with PTFE braided packing ring
HTP265	Carbonized fibre braided packing ring
HTP275	Carboniz fibre braided packing ring
HTP315	Aramid fibre braided packing ring
HTP283	PTFE fibre braided packing ring
HTP245	Acrylic fibre braided packing ring
HTP255	Ramie fibre braided packing ring



NON-ASBESTOS SHEET

HI TECH NO. HTS200 SERIES

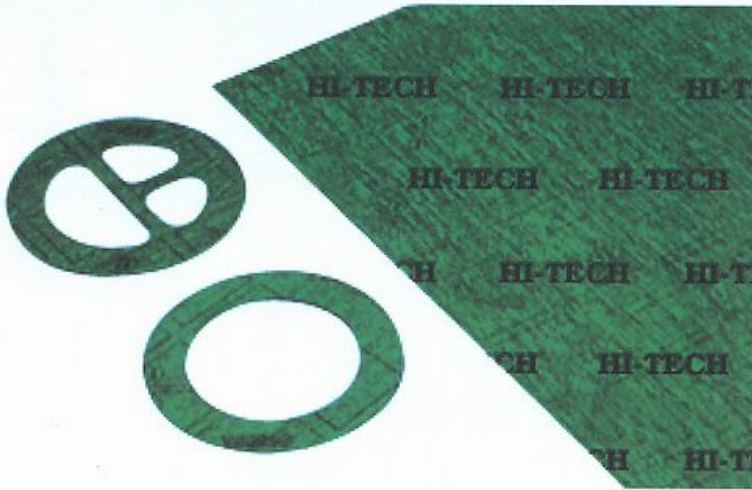

This products is made from "Kevlar" Aramid fiber, Vegetable fiber, Mineral fiber, compressed and calendered under high temperature and pressure into a sheet form. It eliminates asbestos-rubber sheet essentially and thoroughly.

Oil resisting non-asbestos sheet is made from Kevlar fiber, synthetic rubber, filling material and dye, compressed and calendered under high temperature and pressure into a sheet form.

Main Properties

Length (mm)	Width	Thickness	Density(g/cm ³)
1520 / 2000 / 4000	1520	0.5, 1.0, 1.5, 2.0, 3.0, 4.0, 5.0	1.8 ~ 2.0

Main Properties

Colour	Black	Red	Green-White
Style	210	220	230
Temperature°C	400	300	300
Pressure (Mpa)	10	7	7
Compressibility (%) ASTM F36	7-17	7-17	7-17
Recovery (%) ASTM F36	>45	>45	>45
Horizontal Tensile Strength (N/mm ²) ASTM F52	10	12	15
Oil Resistance ASTM No.3 Oil - 5h 150°C	0-5	0-5	0-5
Thickness Increase (%)	≤ 10	≤ 10	≤ 10
Weight Increase (%)			
Variation of Tensile Strength (N/mm ²) ASTM F152	-30	-30	-30
Leakage rate (ml/min) DIN 3535/4	0.5	0.5	0.5
Ignition loss (%) JB/T 6628 (Under 300°C Temp igniting for 3 hours)	≤ 8	≤ 8	≤ 25
Stress Relaxation (N/mm ²) DIN 52913	≤ 25	≤ 25	≤ 25

Above Products Can be reinforced with tin steel wire mesh, copper wire mesh and AISI304 wire mesh etc.



CORK & RUBBER CORK SHEET

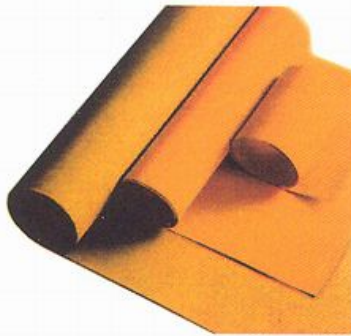

HI TECH NO. HTS5900

Cork Sheet & Cork Rubber Sheet

Length (mm)	Width (mm)	Thickness(mm)
940, 915	640, 610	1, 1.5, 2, 3, 4

Composition Cork is made from selected granulated cork, bonded together using different synthetic or natural binding agents. The unique cellular structure of cork gives composition cork a whole range of benefits. Elasticity is particularly important when gaskets are exposed to varying pressure and temperature over long periods of time under extreme temperature and liquid immersion conditions.

Rubber Cork is produced from high-grade cork granules mixed with synthetic/natural rubber binders (neoprene, nitrile, SBR or natural). This combines the resilience of rubber with the natural compressibility of cork. More than 50% of cork's volume is accounted for by air within the cork cells, hence compression does not produce lateral spread and the high strength of the cell walls ensures good recovery properties. The more flowing characteristics of rubber, its ability to withstand high vacuums and the action of hot oils, are all desirable features of good gasket materials.

Cork in Electrical Industry - Special Cork and Rubber materials have been developed to prevent leakage of the cooling fluids used in modern electrical transformers. Similar materials are also widely used in switchgear circuit breakers, lightning arresters and other transmission equipment, etc.

EXPANDED GRAPHITE SHEETS & ROLLS

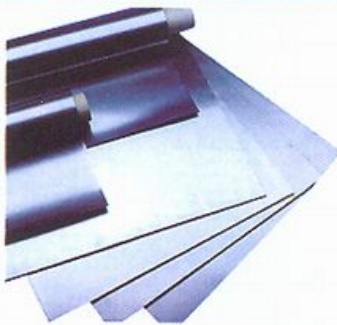

HI TECH NO. HTP100 SERIES

Sheet Size

Density(g/cm ³)	Length(mm)	Width(mm)	Thickness(mm)
0.7 - 1.2	≤ 2000	≤ 2000	0.2 - 10.0

Roll Size

Density(g/cm ³)	Length(mm)	Width(mm)	Thickness(mm)
0.7 - 1.1	30 - 100	≤ 1500	0.2 - 0.8

Service Range

Temperature(°C)		Pressure (Mpa)	PH Range
In oxidizing atmosphere	In non-oxidizing atmosphere		
-240 ~ 450	-240 ~ 3500	30	0 ~ 14

Main Properties

Project	I	II
Tolerance of density (g/cm ³)	±0.05	±0.06
Tolerance of thickness (mm)	±0.03	±0.04
Carbon Content (%)	99.8	98
Tensile Strength (Mpa)	m 4.5	m 4.5
Compressibility (%)	m 40	m 40
Recovery (%)	m 10	m 10
Sulphur Content (PPM)	<700	<1000
Chlorine Content (PPM)	<25	<50
Stress relaxation (%)	10	10
Ignition Loss(%)	<0.5	<0.1

Expanded Graphite Sheet & Roll are selected from the high purity natural flake graphite. They are made through the advanced chemical treatment and mechanical procedure etc. This products enhance excellent properties such as thermal stable, with stand high and low temperature, corrosion, resistance. It has been widely used for die formed packing rings and various kinds of gaskets. It is a basic material for making different kinds of graphite seals. Special specifications can be ordered on customer's demands.



REINFORCED EXPANDED GRAPHITE SHEET

This product is made from materials of three layers. At the middle of the composite plate is a stainless steel plate and on both sides expanded graphite plates. Then, through specially pressing or sticking process, after that, the product is done.

This is a kind of sealing packing with excellent comprehensive properties. It overcomes the disadvantage of being squeezed out from and or sticking into flanges.

HI TECH NO. HTS110 SERIES

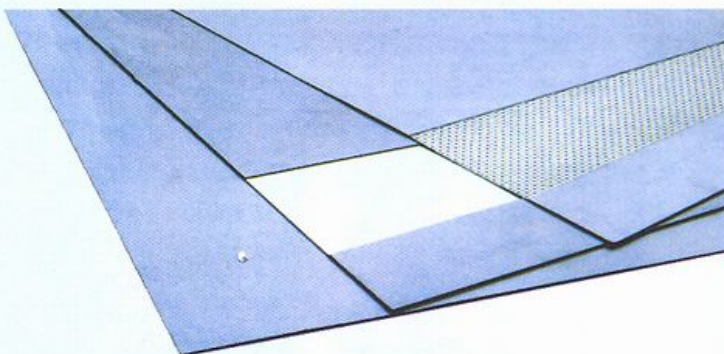

Style	Length(mm)	Width(mm)	Thickness(mm)
Reinforced Tanged insertion	≤ 1500	≤ 1500	1.0 - 5.0
Flat Adhesive bond Insertion	≤ 1500	≤ 1500	0.8 - 5.0

Service Range

NO.	Reinforced Inserted Material	Construction	(N/mm ²) Stability Under Compressive Stress	Temperature(°C)		ASTM F36A-66 Compressibility %	ASTM F36A-66 Recovery %	DN3535 Gas Permeability cm ² /min	Thickness 1.5mm	
				In oxidizing Media	In Non oxidizing Media				ml/hr N ²	
HTS111	Tanged Carbon steel Sheet (Thickness 0.20 - 0.25mm)		≥ 48	-10 - 450	-10-500	30 - 35	15 - 20	≤ 0.8	30	<0.5
HTS112	SS304, 316/ L, AISI304, 316/ L, etc. Tanged stainless steel Sheet (Thickness 0.1mm)		≥ 48	-240 -450	-200 -560 (SS304) -200 -870 (SS316 / L)	30 - 40	15 - 30	≤ 0.8	60	<0.5
HTS113	SS 304, 316/ L, AISI 304, 316 / L etc stainless steel flat sheet (Thickness 0.05,0.1mm)		≥ 45	-240 -450	-200 -560 (SS304) -200 -870 (SS316 / L)	40 - 50	10 - 15	≤ 0.4	35	<0.5
HTS114	SS304, 316/ L, AISI304, 316/ L, etc stainless steel mesh		≥ 40	-240 -450	-200 -560 (SS304) -200 -870 (SS316 / L)	30 - 35	15 - 20	≤ 1.0	7000	58

This kind of packings has good compressibility and resilience, small stress relaxation, fine compensation function for unevenness of sealing surfaces and long working life. These plates are suitable for making gaskets of cylinders for air compressors, internal combustion engines and packings for different kinds of pipings and flanges.



PTFE SHEET GASKET & SEALS

HI TECH NO. HTG900 SERIES



Made from quality PTFE resin, powdered graphite, MoS₂, high temperature-resistant Lubricants and glass fiber through press shaping and sintering. PTFE products include sheet, rod, tube, tape and gasket, ect. They are moulded, sliced or cut from 100%virgin PTFE. It has the best chemical corrosion resistance among known plastics, range from 180°C to 260°C without being aging, lowest friction co-efficient and wear resistance.

Applications:

Sealing under ambient temperature up to 260°C

Supply Range :

Sheets, tubes, rods, "O" ring, gaskets, fillers and seals.

SEALON SHEET(GASKET), JOINT SEALANT & ROPE

HI TECH NO. HTG910 SERIES



A novel inner structure-purpose fibrous sealing material made of PTFE resin through special process, low in density and creep, good in compression resilience, and easy in use and assembly.

Temperature : -200 ~ 280°C

Pressure : < 20 MPa

PH Value : 0~14

Used as seals for flanges, box connectors and valves

Supply Range

Sheets	1500x1500mm	Thickness: 0.5 ~ 6.0mm
Gaskets	Diameter < 1500mm in various shape	
Joint Sealant	Width: 3 ~ 50mm	Thickness: 2 ~ 8mm
Ropes	Diameter: 3 ~ 25mm	

